

### Features:

- Special lead configurations
- 100% RoHS compliant and lead free without exemption
- Halogen free
- REACH compliant



### Electrical Specifications – Lead Style 01

Type / Code	Power Rating (W) @ 70°C	Maximum Working Voltage (V)	Maximum Overload Voltage (V)	Wirewound Resistance Range (Ω) and Tolerance	Metal Oxide Resistance Range (Ω) and Tolerance
				5%, 10%	5%, 10%
NSZ5...-01	5	350	700	0.22 - 220	240 - 51K
NSZ7...-01	7	500	1000	0.39 - 470	510 - 51K
NSZ10...-01	10	700	1400	0.56 - 680	750 - 51K

$$\text{Max Voltage Rating} = \sqrt{P \cdot R}$$

### Electrical Specifications – Lead Style 03

Type / Code	Power Rating (W) @ 70°C	Maximum Working Voltage (V)	Maximum Overload Voltage (V)	Wirewound Resistance Range (Ω) and Tolerance	Metal Oxide Resistance Range (Ω) and Tolerance
				5%, 10%	5%, 10%
NSZ5...-03	5	350	700	0.22 - 220	240 - 51K
NSZ7...-03	7	500	1000	0.39 - 220	240 - 51K
NSZ10...-03	10	700	1400	0.56 - 220	240 - 51K
NSZ15...-03	15	700	1400	0.62 - 820	-

$$\text{Max Voltage Rating} = \sqrt{P \cdot R}$$

### Electrical Specifications – Lead Style 04

Type / Code	Power Rating (W) @ 70°C	Maximum Working Voltage (V)	Maximum Overload Voltage (V)	Wirewound Resistance Range (Ω) and Tolerance	Metal Oxide Resistance Range (Ω) and Tolerance
				5%, 10%	5%, 10%
NSZ5...-04	5	350	700	0.22 - 220	240 - 51K
NSZ7...-04	7	500	1000	0.39 - 470	510 - 51K
NSZ10...-04	10	700	1400	0.56 - 680	750 - 51K
NSZ15...-04	15	700	1400	0.62 - 820	910 - 51K

$$\text{Max Voltage Rating} = \sqrt{P \cdot R}$$

### Mechanical Specifications – Lead Style 01

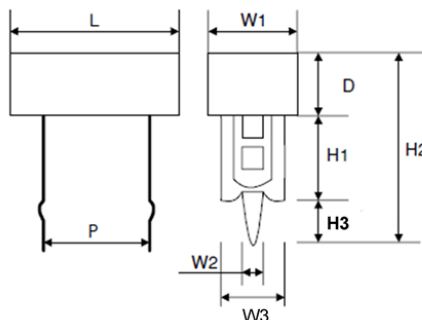

Type / Code	L	P	W1	W2	W3	D	H1	H2	H3	Unit
NSZ5...-01	1.063 ± 0.039	0.591 ± 0.079	0.374 ± 0.039	0.059 ± 0.008	0.287 ± 0.012	0.374 ± 0.039	0.394 ± 0.079	0.945	0.177 ± 0.020	inches
	27.00 ± 1.00	15.00 ± 2.00	9.50 ± 1.00	1.50 ± 0.20	7.30 ± 0.30	9.50 ± 1.00	10.00 ± 2.00	24.00	4.50 ± 0.50	mm
NSZ7...-01	1.378 ± 0.039	0.886 ± 0.079	0.374 ± 0.039	0.059 ± 0.008	0.287 ± 0.012	0.374 ± 0.039	0.394 ± 0.079	0.945	0.177 ± 0.020	inches
	35.00 ± 1.00	22.50 ± 2.00	9.50 ± 1.00	1.50 ± 0.20	7.30 ± 0.30	9.50 ± 1.00	10.00 ± 2.00	24.00	4.50 ± 0.50	mm
NSZ10...-01	1.890 ± 0.039	1.378 ± 0.079	0.374 ± 0.039	0.059 ± 0.008	0.287 ± 0.012	0.374 ± 0.039	0.394 ± 0.079	0.945	0.177 ± 0.020	inches
	48.00 ± 1.00	35.00 ± 2.00	9.50 ± 1.00	1.50 ± 0.20	7.30 ± 0.30	9.50 ± 1.00	10.00 ± 2.00	24.00	4.50 ± 0.50	mm

**Mechanical Specifications – Lead Style 03**

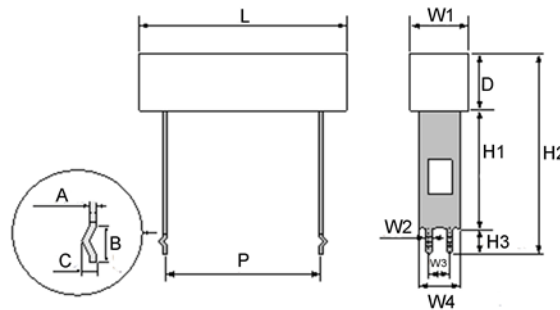

Type / Code	L	P	W1	W2	W3	W4	D	H1	H2	Unit
NSZ5...-03	1.063 ± 0.039 27.00 ± 1.00	0.591 ± 0.079 15.00 ± 2.00	0.374 ± 0.039 9.50 ± 1.00	0.059 ± 0.008 1.50 ± 0.20	0.138 ± 0.020 3.50 ± 0.50	0.287 ± 0.012 7.30 ± 0.30	0.374 ± 0.039 9.50 ± 1.00	0.984 ± 0.079 25.00 ± 2.00	1.535 39.00	inches mm
NSZ7...-03	1.378 ± 0.039 35.00 ± 1.00	0.886 ± 0.079 22.50 ± 2.00	0.374 ± 0.039 9.50 ± 1.00	0.059 ± 0.008 1.50 ± 0.20	0.138 ± 0.020 3.50 ± 0.50	0.287 ± 0.012 7.30 ± 0.30	0.374 ± 0.039 9.50 ± 1.00	0.984 ± 0.079 25.00 ± 2.00	1.535 39.00	inches mm
NSZ10...-03	1.890 ± 0.039 48.00 ± 1.00	1.378 ± 0.079 35.00 ± 2.00	0.374 ± 0.039 9.50 ± 1.00	0.059 ± 0.008 1.50 ± 0.20	0.138 ± 0.020 3.50 ± 0.50	0.287 ± 0.012 7.30 ± 0.30	0.374 ± 0.039 9.50 ± 1.00	0.984 ± 0.079 25.00 ± 2.00	1.535 39.00	inches mm
NSZ15...-03	1.909 ± 0.039 48.50 ± 1.00	1.280 ± 0.079 32.50 ± 2.00	0.492 ± 0.039 12.50 ± 1.00	0.079 ± 0.008 2.00 ± 0.20	0.197 ± 0.039 5.00 ± 1.00	0.394 ± 0.012 10.00 ± 0.30	0.492 ± 0.039 12.50 ± 1.00	1.181 ± 0.079 30.00 ± 2.00	1.870 47.50	inches mm

Type / Code	H3	A	B	C	Unit
NSZ5...-03	0.177 ± 0.020 4.50 ± 0.50	0.020 ± 0.004 0.50 ± 0.10	0.177 ± 0.020 4.50 ± 0.50	0.033 0.85	inches mm
NSZ7...-03	0.177 ± 0.020 4.50 ± 0.50	0.020 ± 0.004 0.50 ± 0.10	0.177 ± 0.020 4.50 ± 0.50	0.033 0.85	inches mm
NSZ10...-03	0.177 ± 0.020 4.50 ± 0.50	0.020 ± 0.004 0.50 ± 0.10	0.177 ± 0.020 4.50 ± 0.50	0.033 0.85	inches mm
NSZ15...-03	0.177 ± 0.020 4.50 ± 0.50	0.020 ± 0.004 0.50 ± 0.10	0.177 ± 0.020 4.50 ± 0.50	0.033 0.85	inches mm

**Mechanical Specifications – Lead Style 04**

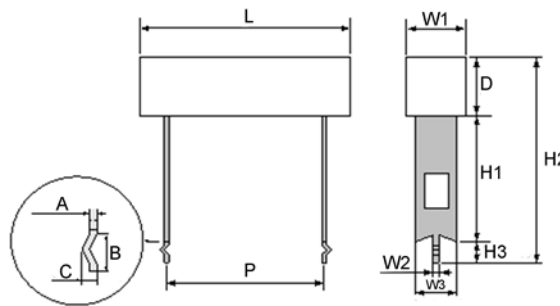

Type / Code	L	P	W1	W2	W3	D	H1	H2	Unit
NSZ5...-04	1.063 ± 0.039 27.00 ± 1.00	0.591 ± 0.079 15.00 ± 2.00	0.374 ± 0.039 9.50 ± 1.00	0.059 ± 0.008 1.50 ± 0.20	0.287 ± 0.012 7.30 ± 0.30	0.374 ± 0.039 9.50 ± 1.00	0.984 ± 0.079 25.00 ± 2.00	1.535 39.00	inches mm
NSZ7...-04	1.378 ± 0.039 35.00 ± 1.00	0.886 ± 0.079 22.50 ± 2.00	0.374 ± 0.039 9.50 ± 1.00	0.059 ± 0.008 1.50 ± 0.20	0.287 ± 0.012 7.30 ± 0.30	0.374 ± 0.039 9.50 ± 1.00	0.984 ± 0.079 25.00 ± 2.00	1.535 39.00	inches mm
NSZ10...-04	1.890 ± 0.039 48.00 ± 1.00	1.378 ± 0.079 35.00 ± 2.00	0.374 ± 0.039 9.50 ± 1.00	0.059 ± 0.008 1.50 ± 0.20	0.287 ± 0.012 7.30 ± 0.30	0.374 ± 0.039 9.50 ± 1.00	0.984 ± 0.079 25.00 ± 2.00	1.535 39.00	inches mm
NSZ15...-04	1.909 ± 0.039 48.50 ± 1.00	1.280 ± 0.079 32.50 ± 2.00	0.492 ± 0.039 12.50 ± 1.00	0.118 ± 0.008 3.00 ± 0.20	0.287 ± 0.012 7.30 ± 0.30	0.492 ± 0.039 12.50 ± 1.00	1.181 ± 0.079 30.00 ± 2.00	1.870 47.50	inches mm

### Mechanical Specifications – Lead Style 04 (cont.)

Type / Code	H3	A	B	C	Unit
NSZ5...-04	0.177 ± 0.020	0.020 ± 0.004	0.177 ± 0.020	0.033	inches
	4.50 ± 0.50	0.50 ± 0.10	4.50 ± 0.50	0.85	mm
NSZ7...-04	0.177 ± 0.020	0.020 ± 0.004	0.177 ± 0.020	0.033	inches
	4.50 ± 0.50	0.50 ± 0.10	4.50 ± 0.50	0.85	mm
NSZ10...-04	0.177 ± 0.020	0.020 ± 0.004	0.177 ± 0.020	0.033	inches
	4.50 ± 0.50	0.50 ± 0.10	4.50 ± 0.50	0.85	mm
NSZ15...-04	0.177 ± 0.020	0.020 ± 0.004	0.177 ± 0.020	0.033	inches
	4.50 ± 0.50	0.50 ± 0.10	4.50 ± 0.50	0.85	mm

### Performance Characteristics

Item	Performance or Quality Acceptance	Test Method															
Temperature Coefficient of Resistance	R < 1 Ω ± 700 ppm/°C R ≥ 1 Ω ± 200 ppm/°C	Measure resistance (R <sub>0</sub> ) at room temperature (t), after that, measure again the resistance (R) at 100°C higher than room temperature $TCR = \frac{R - R_0}{R_0} \times \frac{10^6}{(t + 100) - t} \text{ (ppm/°C)}$															
Overload (Short Time)	Change of resistance ≤ ± (2% + 0.05 Ω)	Apply DC voltage 2.5 times the rated voltage for 5 seconds. Leave it at room temperature for 30 minutes. Then measure.															
Voltage Proof	Change of resistance ≤ ± (0.5% + 0.05 Ω) No mechanical damage.	Lay the resistor on the flat metal plate and apply the specified voltage between tied terminals for one minute. Test voltage (AC): 1500 V															
Insulation Resistance	≥ 1000 Mohm	Lay the resistor on the 90° angle metal V block and apply 500 Vdc between V block and lead wire for a minute. The insulation resistance shall be measured while applying the voltage.															
Vibration	Change of resistance ≤ ± (1% + 0.05 Ω)	Apply 1.5 mm amplitude vibration to three directions perpendicular to each other for 2 hours each, total of 6 hours. Vibrating frequency is 10 Hz - 55 Hz - 10 Hz cycle in 1 minute sweeping and repeat cycle.															
Robustness of Terminations	Change of resistance ≤ ± (0.5% + 0.05 Ω) No mechanical damage.	Tensile: The body of the resistor is fixed, a static load is added in the direction of drawing out of the terminal, and it maintains it for 10 ± 1 seconds. Tensile strength: 45 N 0.5 N is applied from any direction for 10 seconds.															
Resistance to Soldering Heat	Change of resistance ≤ ± (1% + 0.05 Ω)	Dip the lead into a solder bath having a temperature of 260°C ± 5°C up to 1.5 ± 0.5 mm from the body of the resistors and hold it for 10 ± 0.5 seconds and leave in room temperature for 24 hours after test.															
Solderability	More than 95% of the surface of the lead shall be covered by new solder.	Dip the lead into a solder bath having a temperature of 245°C ± 5°C up to 1.5 ± 0.5 mm from the body of the resistors and hold it for 5 ± 0.5 seconds.															
Rapid Change of Temperature	Change of resistance ≤ ± (1% + 0.05 Ω)	The resistor shall be subjected to 5 continuous cycle, each as shown in the table below: <table border="1" style="margin-left: auto; margin-right: auto;"> <thead> <tr> <th></th> <th>Temperature</th> <th>Duration</th> </tr> </thead> <tbody> <tr> <td>1</td> <td>Minimum operating temperature</td> <td>30 minunes</td> </tr> <tr> <td>2</td> <td>Standard atmospheric condition</td> <td>≤ 30 seconds</td> </tr> <tr> <td>3</td> <td>Maximum operating temperature</td> <td>30 minunes</td> </tr> <tr> <td>4</td> <td>Standard atmospheric condition</td> <td>≤ 30 seconds</td> </tr> </tbody> </table>		Temperature	Duration	1	Minimum operating temperature	30 minunes	2	Standard atmospheric condition	≤ 30 seconds	3	Maximum operating temperature	30 minunes	4	Standard atmospheric condition	≤ 30 seconds
	Temperature	Duration															
1	Minimum operating temperature	30 minunes															
2	Standard atmospheric condition	≤ 30 seconds															
3	Maximum operating temperature	30 minunes															
4	Standard atmospheric condition	≤ 30 seconds															
Damp Heat, Steady State	Change of resistance ≤ ± (5% + 0.05 Ω)	In the chamber having temperature 40°C ± 2°C and relative humidity 93 ± 3%, apply one percent of the rated power, 1.5 hour ON, 0.5 hour OFF for 1000 hours and leave in room temperature for one hour after test.															
Endurance at Room Temperature	Change of resistance ≤ ± (5% + 0.05 Ω)	At room temperature, apply rated DC voltage 1.5 ON, 0.5 hour OFF for 1000 hours and leave in room temperature for one hour after test.															

Operating Temperature Range: -55°C to +275°C wirewound; -55°C to + 150°C metal oxide.

### Power Derating Curve:

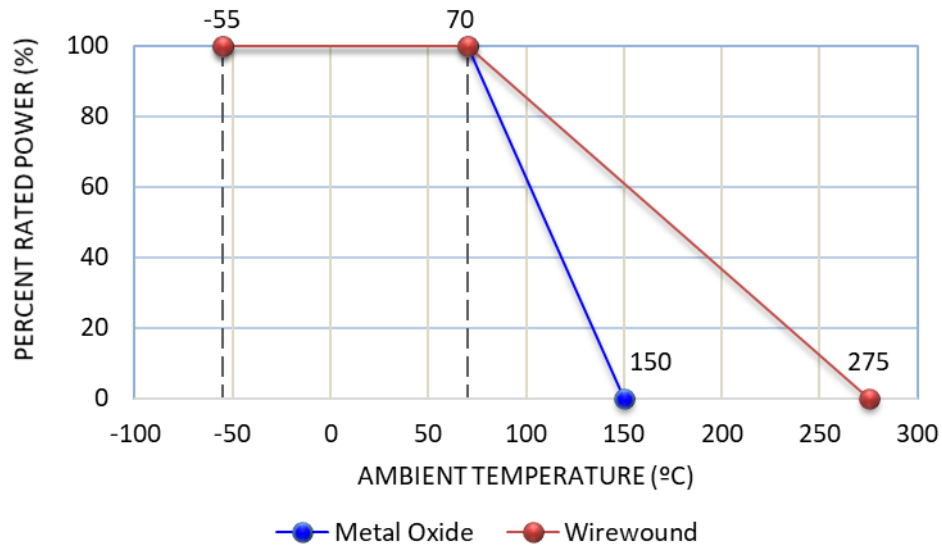

### Recommended Solder Profile

This information is intended as a reference for solder profiles for Stackpole resistive components. These profiles should be compatible with most soldering processes. These are only recommendations. Actual numbers will depend on board density, geometry, packages used, etc., especially those cells labeled with “\*”.

### 100% Matte Tin / RoHS Compliant Terminations

Soldering iron recommended temperatures: 330°C to 350°C with minimum duration.  
Maximum number of reflow cycles: 3.

Wave Soldering			
Description	Maximum	Recommended	Minimum
Preheat Time	80 seconds	70 seconds	60 seconds
Temperature Diff.	140°C	120°C	100°C
Solder Temp.	260°C	250°C	240°C
Dwell Time at Max.	10 seconds	5 seconds	*
Ramp DN (°C/sec)	N/A	N/A	N/A

Temperature Diff. = Difference between final preheat stage and soldering stage.

Convection IR Reflow			
Description	Maximum	Recommended	Minimum
Ramp Up (°C/sec)	3°C/sec	2°C/sec	*
Dwell Time > 217°C	150 seconds	90 seconds	60 seconds
Solder Temp.	260°C	245°C	*
Dwell Time at Max.	30 seconds	15 seconds	10 seconds
Ramp DN (°C/sec)	6°C/sec	3°C/sec	*

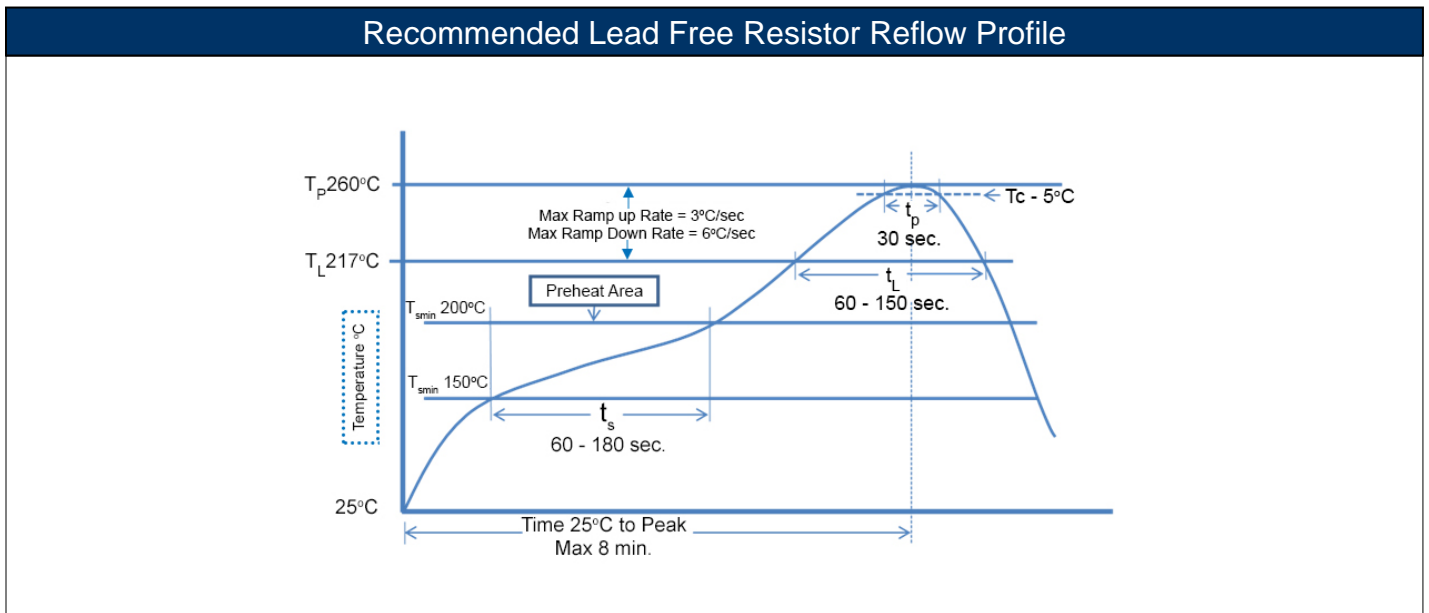

**RoHS Compliance**

Stackpole Electronics has joined the worldwide effort to reduce the amount of lead in electronic components and to meet the various regulatory requirements now prevalent, such as the European Union’s directive regarding “Restrictions on Hazardous Substances” (RoHS 3). As part of this ongoing program, we periodically update this document with the status regarding the availability of our compliant components. All our standard part numbers are compliant to EU Directive 2011/65/EU of the European Parliament as amended by Directive (EU) 2015/863/EU as regards the list of restricted substances.

RoHS Compliance Status						
Standard Product Series	Description	Package / Termination Type	Standard Series RoHS Compliant	Lead-Free Termination Composition	Lead-Free Mfg. Effective Date (Std Product Series)	Lead-Free Effective Date Code (YY/WW)
NSZ	Ceramic Housed Wirewound Resistor with Specialty Leads	Radial	YES	99.3 / 0.7 Sn/Cu	Jan-04	04/01

**“Conflict Metals” Commitment**

We at Stackpole Electronics, Inc. are joined with our industry in opposing the use of metals mined in the “conflict region” of the Eastern Democratic Republic of the Congo (DRC) in our products. Recognizing that the supply chain for metals used in the electronics industry is very complex, we work closely with our own suppliers to verify to the extent possible that the materials and products we supply do not contain metals sourced from this conflict region. As such, we are in compliance with the requirements of Dodd-Frank Act regarding Conflict Minerals.

**Compliance to “REACH”**

We certify that all passive components supplied by Stackpole Electronics, Inc. are SVHC (Substances of Very High Concern) free and compliant with the requirements of EU Directive 1907/2006/EC, “The Registration, Evaluation, Authorization and Restriction of Chemicals”, otherwise referred to as REACH. Contact us for complete list of REACH Substance Candidate List.

### Environmental Policy

It is the policy of Stackpole Electronics, Inc. (SEI) to protect the environment in all localities in which we operate. We continually strive to improve our effect on the environment. We observe all applicable laws and regulations regarding the protection of our environment and all requests related to the environment to which we have agreed. We are committed to the prevention of all forms of pollution.

## How to Order

1	2	3	4	5	6	7	8	9	10	11	12	
<b>N</b>	<b>S</b>	<b>Z</b>	<b>7</b>	<b>J</b>	<b>B</b>	<b>1</b>	<b>K</b>	<b>0</b>	<b>0</b>	<b>-</b>	<b>0</b>	<b>1</b>

Product Series		Power Rating		Tolerance			Packaging				Resistance Value	Lead Style
Code	Description	Size	W	Code	Tol	Value	Cod	Description	Size	Quantity	Four characters with the multiplier used as the decimal holder.	Code
NSZ	Ceramic Housed Wirewound with Specialty Leads	5	5	J	5%	E24	B	Bulk	5, 7, 10	1000	1 ohm = 1R00 680 ohm = 680R 51 Kohm = 51K0	01
		7	7	K	10%	E12			15	500		03
		10	10									04
		15	15									